



**BALTIMORE
AIRCOIL AUSTRALIA**



VFD

OPERATION & MAINTENANCE MANUAL

Introduction

BAC pre-program the Danfoss VLT HVAC FC-102 VFD as per the design conditions provided with the evaporative cooling equipment and the fan motor data at time of manufacture. These factory settings are shown on page 3 and provide the evaporative equipment operator or commissioning personnel the flexibility to start the equipment using the factory pre-programmed settings or to customise any of the control parameters to suit the application or site specific conditions. The Variable Frequency Drive (VFD) has been programmed in PID Control with Auto Start, Sleep Mode and a Set Point Reference.

A Temperature Sensor is factory installed at the outlet of the evaporative cooling equipment which measures the leaving water temperature. Please note that these instructions should be read in conjunction with Danfoss operating, installation and maintenance manuals.

LCD Display Customisation

The VFD LCD Display is customised to show the following values (see figure 1);

Motor RPM - Motor Current (Amps) - Set Point Reference (°C) - Leaving Water Temperature (°C) - Motor Frequency (Hz) - Drive Operating Condition.

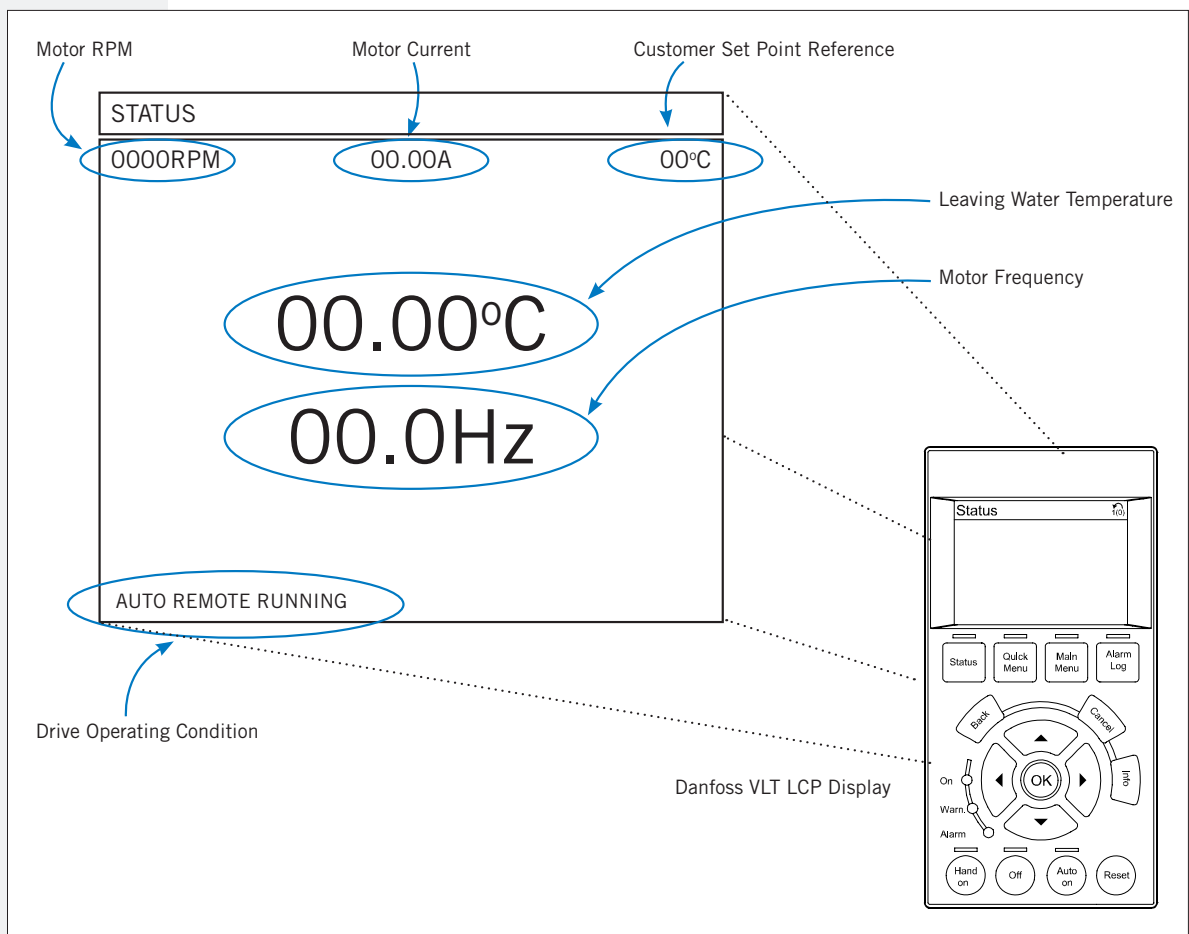

Figure 1.



Commissioning

⚠ WARNING - On power up or energising, the BAC pre-programmed Danfoss VLT HVAC FC-102 VFD will operate in an “Auto ON” condition. Power up or energising of the VFD will cause the motor (fan) to cycle (rotate) for approximately 10 seconds if the leaving water temperature is below the set point reference value and/or “Cycle Start” if the leaving water temperature is above the set point reference value. The set point reference value should be displayed on the VFD LCD screen at power up. Turn the Motor Isolator “OFF”, located on the BAC supplied terminal box (to stop the motor/fan from rotating. Only turn the Motor Isolator ON when it is safe to do so or when site specific lock-out and/or safety procedures have been followed.

1. If temperature is above ‘Set Point’ - Turn isolator ‘ON’ to check.
2. If temperature is below ‘Set Point’ - Turn isolator ‘ON’ and press ‘OFF’ then ‘Hand ON’ on LCP, this will cycle the fan for approximately 10 seconds. Return to ‘Auto ON’ when complete.
3. If necessary change phase for correct direction.
This must be done at one of the following locations:
 - a) VLT output terminals UVW
 - b) The motor isolation switch
 - c) The motor terminal box
4. Test the full speed operation after checking that the fan direction is correct:
 - (a) If the Leaving Water Temperature is above ‘Set Point’ - Turn on power supply and fan isolator.
 - (b) If the Leaving Water Temperature is below ‘Set Point’ - Turn on power supply and fan isolator.
Press Quick Menu - Select ‘My Personal Menu’. Press ‘OK’. Press ▼ down arrow (for direct access to ‘Set Point’).
Press ‘OK’. Change ‘Set Point’ (using ▲▼◀▶ arrow buttons) to be below actual temperature. Press ‘OK’.
Motor will ramp to full speed. Press ‘OK’. Reset ‘Set Point’ to original setting after test. Press ‘OK’.
Press ‘Back’ button twice to return the LCP Display to the main screen.



Figure 2. BAC Intelvap Controller Assembly

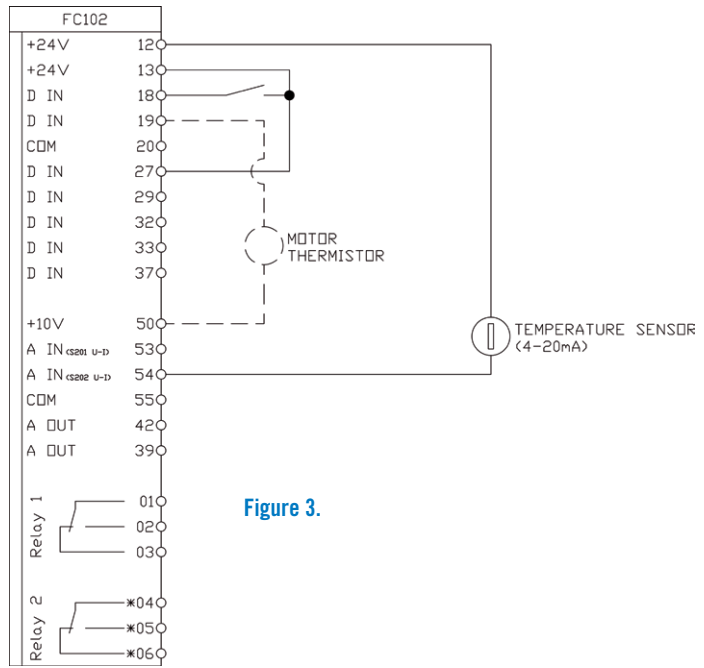

Figure 3.

NOTE: Closed loop operation from 0 - 100°C temperature transmitter with 4-20mA output. The motor needs to speed up when the temperature goes above the parameter 20.21 (Set Point). The PID startup frequency is 25Hz and when the drive is running at a min frequency 25Hz, it will go to sleep. The DIP switch behind the LCP has been changed for 4-20mA signal.

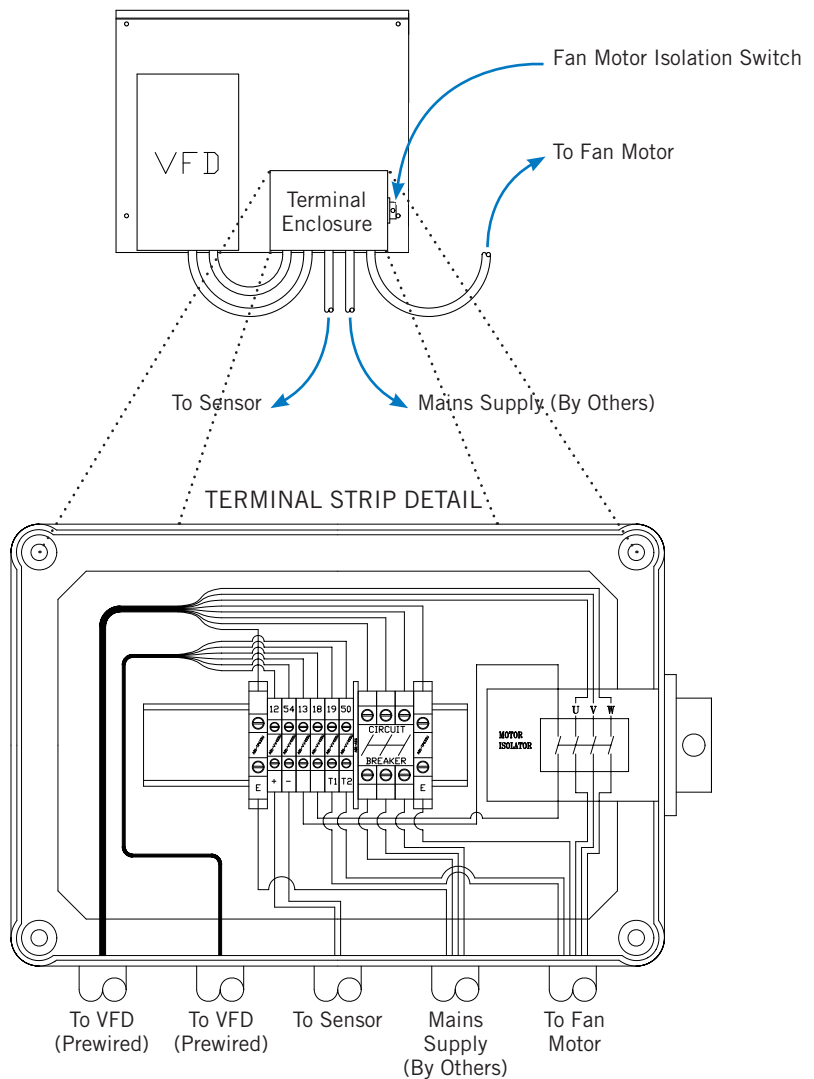

Figure 4.



BAC Customised Factory Settings

Par	Function	Customised Settings
0.20	Display 1.1	1617 RPM (Speed)
0.22	Display 1.3	1602 Reference %
0.23	Display L2	1652 Feedback Unit
0.24	Display L3	Frequency Hz
0.25	Personal Menu	20.21 Set Point
1.00	Configuration	3 Closed Loop
1.03	Variable Torque	1
1.20	kW	[Motor Name Plate]
1.22	Volts	[Motor Name Plate]
1.23	Hz	[Motor Name Plate]
1.24	Amps	[Motor Name Plate]
1.25	RPM	[Motor Name Plate]
1.71	Start Delay	10 sec.
1.73	Flying Start	Enable
1.90	Thermistor	2 Trip
1.93	DIN 19 Input	4 Therm. Source
3.03	Max. Reference	100
3.15	Reference Source 1	0 No Function
3.41	Ramp Up Time	20 sec.
3.42	Ramp Down Time	20 sec.
4.12	Motor Speed Low	25Hz
4.14	Motor Speed high	50Hz
5.12	DIN 27 Input	54 Auto Start
6.01	Sensor Time Out	2 Stop
20.12	Unit	60°C
20.21	Set Point	[based on design duty] °C
20.73	Min. Feedback	0
20.74	Max. Feedback	100
20.81	PID Control	1 Inverse
20.83	PID Start Hz	25Hz
20.93	Proportional Gain	2
20.94	Integral Time	10
22.22	Low Speed Default	1 Enable
22.23	No Flow Function	1 Sleep Mode
22.44	Wake-up Reference	0%

General Variable Frequency Drive Operation

- ▶ Applications utilising variable frequency drives (VFDs) for fan motor control must use inverter duty motors built in compliance with AS 1359.
- ▶ Operation of the unit at a speed which resonates with components of the drive system or support structure may result in vibrations which could damage the components or structure, and/or create objectionable noise. Therefore, these resonant speed ranges should be identified at start-up and locked out to prevent the VFD to operate the motor at these resonant speeds.

Figure 5a. Accelerometer Location - Gear Drive

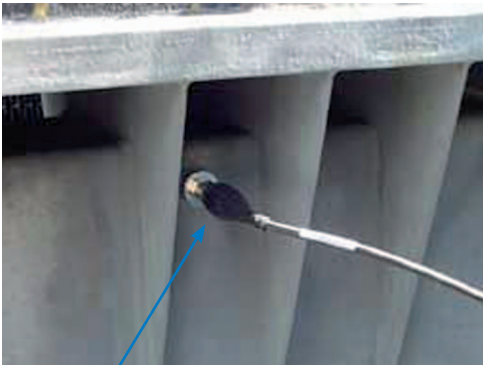

Correct accelerometer location, 1" from the edge of the box beam

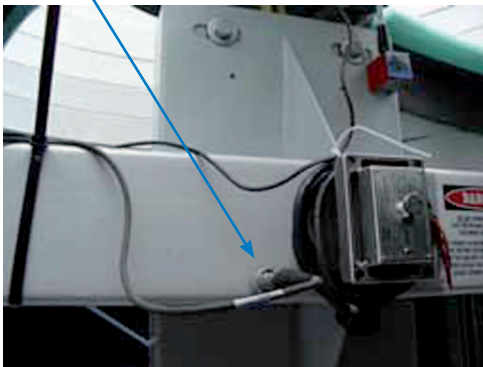

Figure 5b - Accelerometer Location - Belt Drive

▶ At start-up, slowly increase the output of the variable frequency drive to control the fan motor from 0 to increase the maximum motor speed, while monitoring the vibration level and listening for unusual noise. A resonant speed is characterised by a sharp increase in vibration or noise as the speed is slowly increased then peaks and drops back down to acceptable levels as the speed is further increased. The speed range with the elevated vibration and/or noise level should be locked out to prevent operation at these resonant speeds. There may be more than one resonance and therefore more than one lockout speed range within the operating speed range of the unit.

▶ Please refer to the manufacturer's variable frequency drive recommended start-up procedure for further information or consult with your local BAC Balticare Representative for any VFD applications.

Gear Drive Units with VFDs

▶ Do not operate the standard gear drives below 450 RPM motor speed (gear input speed). For speeds less than 450 RPM, a low speed option gear drive must be supplied.

▶ Continued operation at a speed which resonates with the gear drive system may result in torsional vibrations which can damage system components. The most common indicator of torsional vibration is an unusual rumbling or grinding noise from the gear drive at a narrow speed range. The noise will decrease to normal levels when the speed is increased or decreased away from the resonant speed range. This noise is not indicative of a defect, but results when the vibratory torque exceeds the drive torque, causing the gear teeth to separate and clash together very rapidly. On variable frequency drive applications, avoid operation near this resonant speed by locking out the resonant speed range.

Resonant Speed Identification Procedure

There are several characteristic frequencies at which vibration levels may resonate with unit structural components. These include fan speed, motor speed, gear mesh frequency, bearing frequency, and blade pass frequency. Within the overall operating speed range of a unit, it is not unusual for one or more of these characteristic frequencies to excite the structural components over relatively small speed ranges and create an increase in vibration levels. If the vibration levels are excessive at these resonant speeds, they need to be locked out to prevent the VFD from operating the motor at these speeds. The following procedure describes how to identify the lockout speed ranges:



- ▶ Ensure the VFD that controls the fan motor is off, and the power to the motor circuit is locked out.
- ▶ Depending on the type of drive system (gear or belt), attach the accelerometer onto the box beam as shown in Figure 5a or 5b. The accelerometer should be located away from the centre of the web of the box beam, such that the centre line of the accelerometer is about 25mm from the upper or lower edge, as shown.
- ▶ Connect the signal wire from the accelerometer to the vibration analyser. Be sure to route and fasten the wire so that it will not contact any rotating parts inside the cooling tower when the drive system is operational.
- ▶ Get out of the unit, and ensure that the drive system is “all clear”. Remove the lockout from the motor circuit.
- ▶ With the VFD off, record the vibration level indicated on the vibration analyser, and confirm that it is very low (only picking up ambient vibration). Record this overall vibration level (0-peak) in inches per second (ips). If the ambient vibration level is greater than 0.05 ips, identify and correct the cause of the vibration. It could be vibration transmitted from another source, instrumentation malfunction, radio frequency interference, . If the cause is vibration transmitted from another source, and that source cannot be isolated or turned off for the duration of the measurements, note the source and magnitude of the vibration before continuing.
- ▶ After it is confirmed that the drive system is “all clear” and the tower access doors are closed, turn the VFD on, and verify that the fan is turning in the correct direction.
- ▶ Using the VFD, slowly (about 1 RPM increase every five to ten seconds) adjust the motor speed from the lowest limit to full speed while monitoring the vibration levels. Record the overall vibration levels at regular intervals if desired.
- ▶ As stated previously, when adjusting the VFD speed, proceed slowly while monitoring the vibration levels. If the vibration value approaches 0.35 ips (0-peak), slowly “zero in” on the speed where the value equals 0.35 ips, and record the speed at which this occurs as the lower end of the lockout range. Also record the vibration level at this speed.
- ▶ Continue to slowly increase the speed while monitoring the vibration level. If this is a resonance, then the value should peak and eventually decrease to a level that is below 0.35 ips as the speed is increased. After the vibration level has peaked and continues to fall, record the speed where the value equals 0.35 ips as the upper end of the lockout range.
- ▶ Using this data, a baseline for vibration history can be developed. The vibration levels can be monitored periodically and the trend used to indicate potential wear or the need to replace components in the drive system.
- ▶ After the entire speed range has been checked and any resonances identified, ensure the VFD that controls the fan motor is then turned off, and the power to the motor circuit is locked out.
- ▶ Enter the unit, and carefully remove the accelerometer, along with any associated wiring from the tower.
- ▶ Work with the VFD contractor to enter the lockout speed ranges into the VFD, so the tower will not operate at a resonant speed.
- ▶ Once it has been verified that the drive system is all clear, return the tower to its normal operating condition.
- ▶ Keep a record of any lockout speed ranges for future reference.

COOLING TOWERS

CLOSED CIRCUIT COOLING TOWERS

ICE THERMAL STORAGE

EVAPORATIVE CONDENSERS

HYBRID PRODUCTS

PARTS & SERVICES



www.BaltimoreAircoil.com.au